

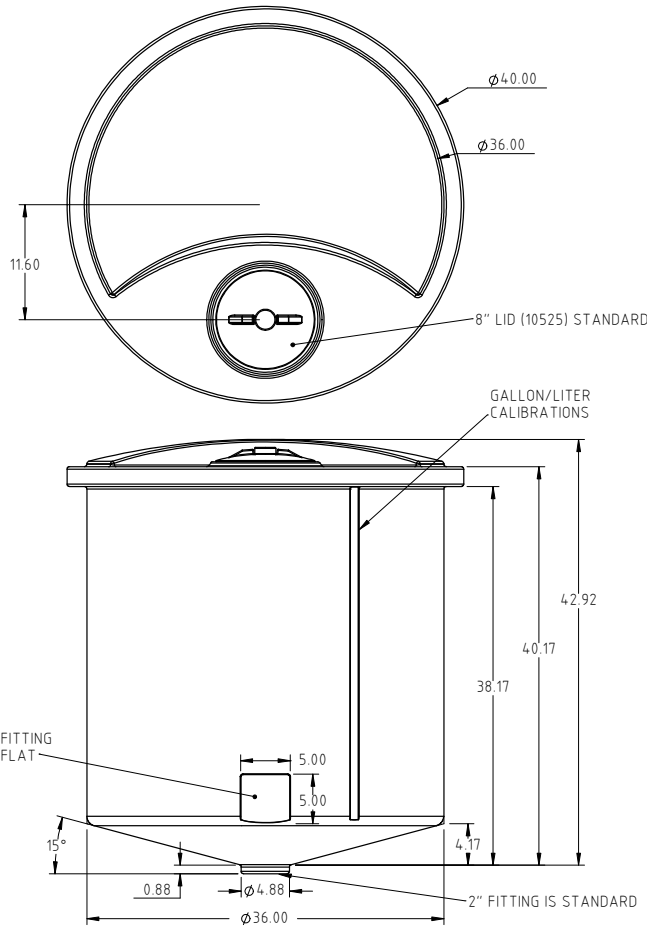

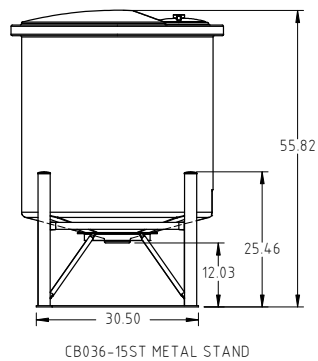
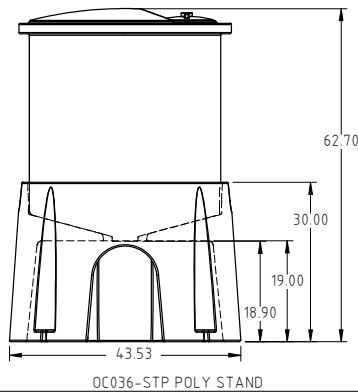

CB0145-36

© DEN HARTOG INDUSTRIES, INC.

Copyright: All information furnished within this document, electronic file or design correspondence is the property of Den Hartog Industries, Inc. and shall not be used, disclosed to others or copied without the expressed written consent of Den Hartog Industries, Inc.



				DRAWN / DATE ADH 7/12/10	MATERIAL 10420
				APPRD. / DATE REH 4/18/11	
REV	DESCRIPTION	BY / DATE	CCN	SHOT WEIGHT: 50.00 LBS	NOTES:
				SHIPPING WEIGHT: 52.00 LBS	1.) 0.20 WALL THICKNESS
				FINISH:	



Den Hartog
INDUSTRIES, INC.

Ace Roto-Mold Injection Molding Slow Molding Sowjoy

4010 HOSPERS DRIVE S. BOX 425, HOSPERS, IOWA 51238-0425

DESCRIPTION	36" DIA. X 145 GALLON CONE BOTTOM	
SCALE	N.S.	PART NO. CB0145-36