



PROPRIETARY DATA

PROPERTY OF ACE ROTO-MOLD MFG, INC. INFORMATION FURNISHED HEREIN IS THE PROPERTY OF ACE ROTO-MOLD MFG, INC AND SHALL NOT BE USED, DISCLOSED TO OTHERS, OR COPIED WITHOUT THE EXPRESSED WRITTEN CONSENT OF ACE ROTO-MOLD MFG, INC. ALL RIGHTS RESERVED.

HE0850-C



KEY	PART NUMBER	MATERIAL	DESCRIPTION	QTY.
1	HE0850-C-1	S-14GA	SHEET, 14 GA	74" X 78"(5772 SI)
2	HE0850-C-2	S-12GA	SHEET, 12 GA	11.75" X 74"(869.50 SI)
3	HE0850-C-3	B02500X20000	FLAT, 1/4 X 2	2 @ 34.50"(69 IN)
4	HE0850-C-4	B02500X30000	FLAT, 1/4 X 3	6 @ 20"(120 IN)
5	HE0850-C-5	A01875X20000	ANGLE, 3/16 X 2	2 @ 74"(148 IN)
6	HE0850-C-6	A02500X40000	ANGLE, 1/4 X 4	4 @ 57 7/8"(231.00 IN)
7	HE0850-C-7	S-14GA	SHEET, 14 GA	2.5" X 78"(195 SI)

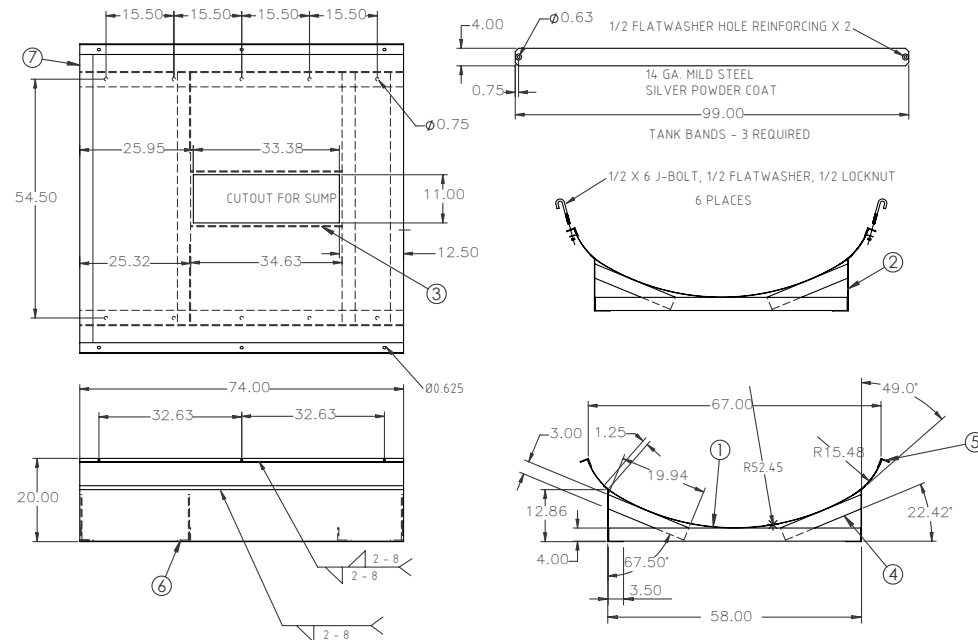

C	TOLERANCE WAS 5% @ 68°F	GWC 3/8/07		DRAWN / DATE	MATERIAL
B	ENLARGE SUMP CUTOUT	1/5/06		ADH 7/23/07	
A	ENLARGE SUMP CUTOUT	5/23/05		APPRD / DATE	
REV	DESCRIPTION	BY / DATE	CCN	REH 10/5/07	
ALL DIMENSIONS ARE IN DECIMAL INCHES TOLERANCES UNLESS OTHERWISE SPECIFIED DECIMAL ± .125" FRACTION ± 1/4" ANGLE ± 1°				THIRD ANGLE PROJECTION ANSI 14.5M 	NOTES:

Den Hartog
INDUSTRIES, INC.

Ace Roto-Mold Injection Molding Blow Molding Sowjoy

4010 HOSPERS DRIVE S. BOX 425, HOSPERS, IOWA 51238-0421

DESCRIPTION ACE 850 GALLON ELLIPTICAL TANK AND CRADLE ASSEMBLY	
SCALE N.S.	PART NO. HE0850-C